



# Look at American Technology... See the Difference.

## LOW PROFILE INTERIOR LIGHTING

double overall  
8" x 3.5" x 1.46"  
dimensions

PN# AT-ILP-2



push  
SEPARATE  
switches

single overall  
4.25" x 3.5" x 1.46"  
dimensions

PN# AT-ILP-1



on/off  
3-WAY  
switches

most  
POPULAR  
o.e.m. colors

patented  
QUICK MOUNT  
cam locks

These all new interior lights will quickly become the standard by which all interior lights will be rated.

From O.E.M. styling and servicability, to low profile quick mount (patented) cam locks for simple install.

Both single and double lamp assemblies feature 3 way switches for up to two power inputs (IE: both ignition and or courtesy light functions).

These lights have both UL and CSA certification.

Units are molded in high impact ABS and the lens assemblies are molded in rugged polycarbonate for years of trouble free high performance operation.

The snap on bezels hide the fasteners to complete the installation.

3-YEAR/36-MILE  
\*LIMITED WARRANTY

\*EXCLUDES LIGHT BULB

CALL US TODAY WITH YOUR  
APPLICATION!

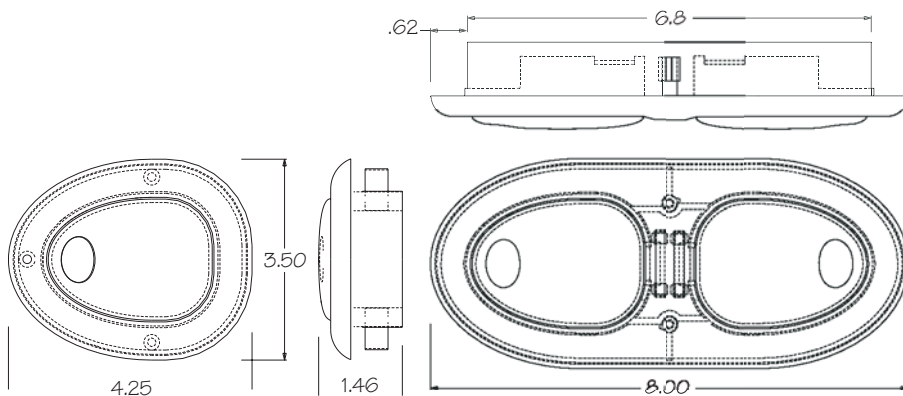

## PRODUCT CERTIFICATION

complete assembly  
switch and socket  
reflector  
wire assembly

CSA NTRL/C  
GM-TFE  
FORD Q-I  
MIL-2000

V-Sales Company  
2016 Borneman Ave.  
Elkhart, Indiana 46517  
Toll-free: 800-528-7953  
www.v-sales.com

